

Mechanical drawing

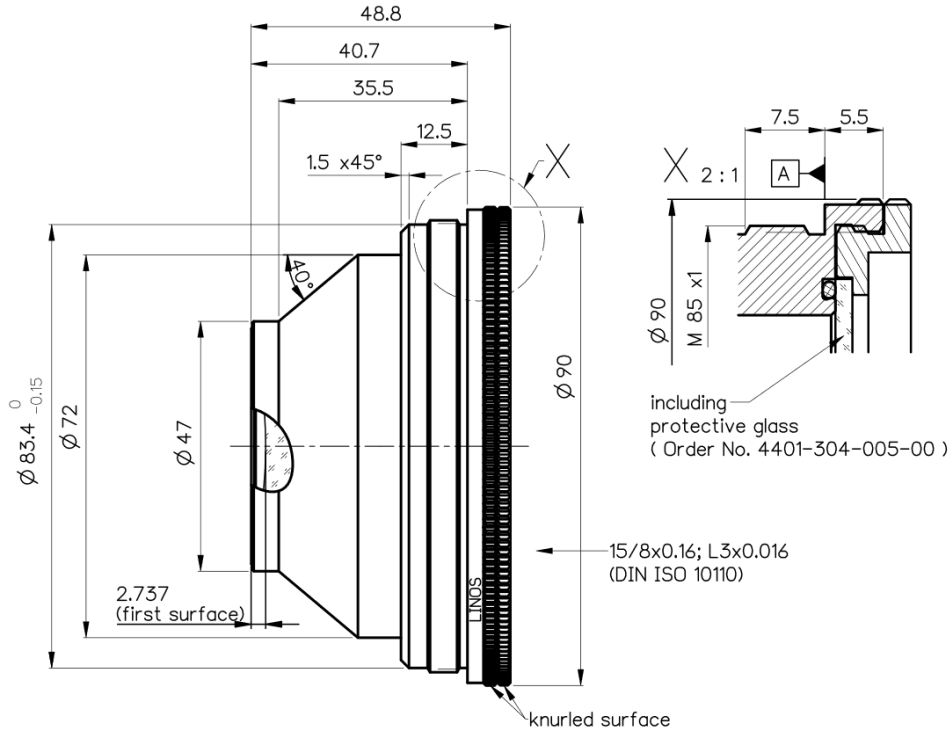

Dimensions without tolerances are nominal values and illustration not to scale

Spot variation over scanfield

Spot radius in μm at $1/e^2$ level for a Gaussian laser beam ($M^2=1$)
field size and mirror distances as given above for a 2 mirror scan system

10mm diameter at $1/e^2$ truncated

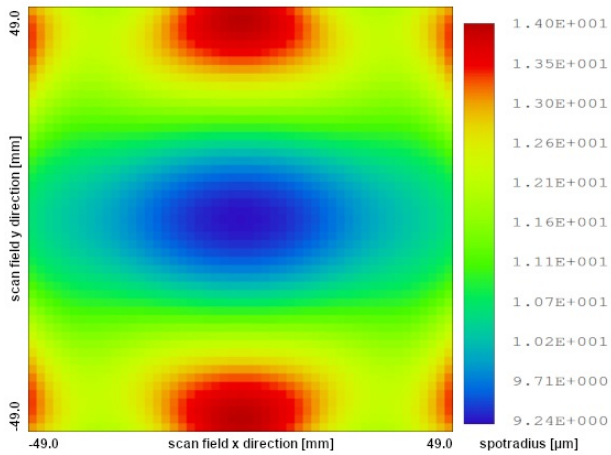

Notes



For technical explanations, see our homepage.

In a 1-mirror system, the entrance pupil (EP) is the position of the scan mirror. In a 2-mirror system, it is the point where the scan mirrors should be placed around symmetrically to reach specified performance.